

SS FF118SQ

DANTE Sq Double Bowl Sink and Drainer

SPECIFICATIONS

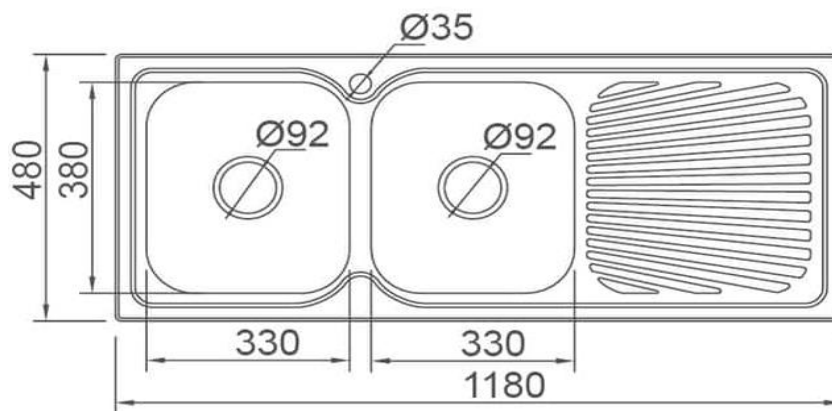

2x20L Capacity

0.8mm 304 Grade Stainless Steel

Left or Right Hand Bowl Available

CLEANING & MAINTENANCE:

All Sinks should be cleaned with mild detergent and water

All Products must be cleaned with a soft cloth with soapy water, avoid waxes, solvents, abrasives, acids and other chemical based cleaners

Warranty will be void if damages are caused by unsuitable cleaning products

WARRANTY INFORMATION:

25 Year Parts or Products Replacement Warranty

1 Year Replacement Warranty on Waste Plugs

All products (Excluding Waste Plugs) have a full 1 year in house labour warranty from date of purchase