



AP-5DA17160AU 70cm Fan Module

Features & Benefits

Easy Cleaning

Stainless steel finish for easy cleaning. Grease filters are dishwasher safe for easy cleaning.

Vision Comfort

Neutral colour lighting with wide downward illumination help with creating a perfect cooking experience.

Controls

Soft button controls located on the base of the appliance.

Stylish

Dark steel finish appliance is integrated to the kitchen, making it more elegant.

Programs

Extraction mode with 3 power levels
Recirculation mode (requires carbon filter)

Energy Source

Electric

Specification

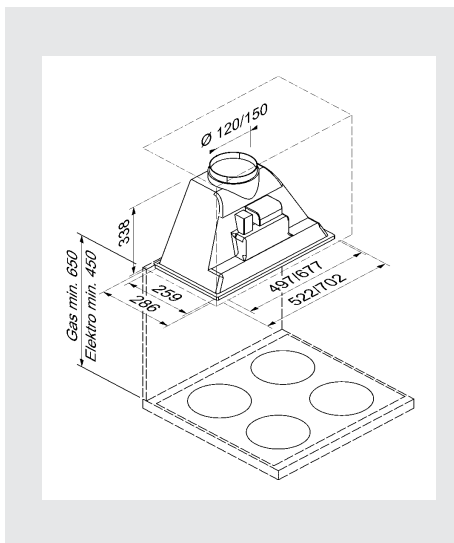

Dimensions

Appliance:
H337.5 x W702 x P286mm

Material

Grease filter: Aluminium
Surface: Stainless Steel

Finish

Stainless steel

Grease Filter

Dishwasher safe: Yes
Odour filter: Optional

Weight

Net: 5.2kg

Type

Built-in

Control

Push button

Lighting

4W LED lamps x 2
Temperature: 4,000K
Illuminance: 100 lux

Extraction

Direction: Upward
Power: 250-590m³/h

Noise

Minimum: 47dB
Maximum: 63dB

Connection

- Voltage: 220-240 V
- Total connected load: 160 W
- Frequency: 50 Hz
- Installation: Built-in
- Energy Source: Electric
- Approval certificates: RCM
- Required distance from induction hob: 450mm
- Required distance from gas hob: 650mm
- Appliance dimensions: 337.5 x 702 x 286 mm
- Packaging dimension: 425 x 785 x 365 mm
- Exhaust air outlet area: 150/120mm
- Height of the unit without chimney: 337.5mm
- Length of connection cable: 150cm
- Connection type: Australian
- Position of fan: Motor in the housing
- Housing material: Plastic
- Flow direction: Upwards
- Maximum sound power: 63dB
- Number of lamps: 2 LED lamps
- Total power of lamps: 8W

Accessories

