



AP-5RG94350AU 90cm Ceramic Cooktop



Features & Benefits

Easy Cleaning

Frameless, flush installation to reduce cleaning surface. Glass top means a regular kitchen surface cleaner should be enough.

Efficiency

Startup-booster for quick heating of cooking zones for lower wait time.

Stylish Design

Sleek glass look in black colour that suits any modern style.

Space Saving

Flush installation integrates the surface for a wider workstation space. Slim and flat design requires less space for installation.

Safety Feature

Child lock and residual heat indicators on each zone to avoid accidents. Time limitation and overflow detection turns off the appliance when unmonitored.

Multiple Cooking Zones

4 zones that can be simultaneously used. Zone extension possible. Each zone has 10 power levels.

Display and Controls

Touch control panel and digital LED display located in front. Smart pot detection for automatic control.

Energy Source

Electricity

Specification

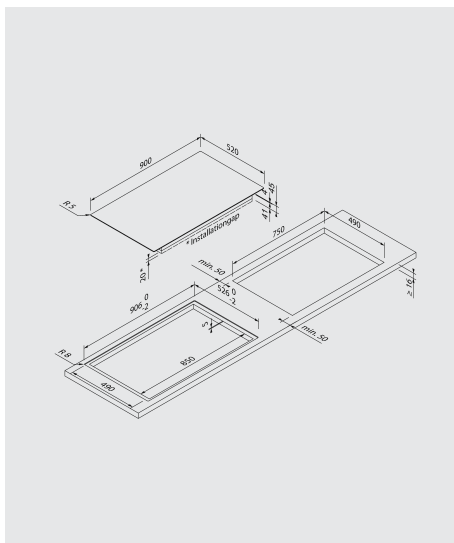

Dimensions

Appliance:
W900 x D520mm
Installation:
H41 x W750 x D490mm

Material

Surface: Glass ceramic

Weight

Net: 11.50kg
Gross: 12.65kg

Type

Built-in, frame-less ceramic hob

Finish

Black

Cooking Zone and Power

2 zones Ø 155mm
– 1.2 kW
1 zone Ø 180-275mm
– 1.5 - 2.4 kW
1 zone Ø 145-220mm
– 1 - 2.2 kW

Control

Touch control panel located in front

Display

LED display
Residual heat indicator

Connection

- Voltage: 220-240 V
- Total connected load: 7 kW
- Frequency: 50/60 Hz
- Device color: Black
- Energy Source: Electric
- Approval certificates: CE
- Length of connection cable: 110cm
- Minimum worktop thickness: 16mm

Accessories

