



BLAUPUNKT



AP-5B36P0250AU 60cm Built-in Pyrolytic Oven

Features & Benefits

Easy Cleaning + Pyrolytic Function

Removable door, enamelled smooth oven walls and suspended grills for easy cleaning. Pyrolytic integrated cleaning in just a push of a button.

Cooling Assist

Built-in cooling fan function to cool down the oven and other objects that needs aeration.

Heat Trap

Full glass inner door combined with an internal oven light for viewing so there is no need to open the door, releasing the heat.

Fast Heating

Quick heating plus enamelled cooking chamber assists in faster oven heating.

Temperature Regulation

Recommends perfect cooking temperature.

Child Safe

Triple glazed glass creates a low door temperature which prevents serious burns from accidental contact. Childproof lock function plus a safety switch-off in case of emergency.

Comfort

Large oven interior of 70L with 1-way telescopic extension.

Energy Efficient

Energy efficiency class A. 220-240 V with a total connected load 3.2kW.

8 Functions

- Top/bottom heat
- Bottom heat
- Fan force Eco
- Fan force
- Fan force grill
- Vario large area grill
- Vario small area grill
- Defrost

Display and Controls

2 fully retractable dial knobs, electronic clock and digital display for control.

Heating

Electric

Timer

Off, On, Alarm

Specification

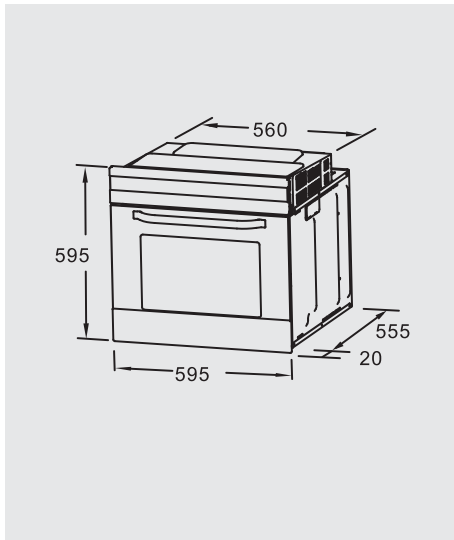

Dimensions

Appliance:
H595 x W595 x D575mm
Installation:
H590 x W560 x D550mm

Screen Height

96mm

Weight

Net: 33 kg

Volume

Net: 70 litres

Type

Built-in

Material

Door: Glass
Panel: Stainless Steel
Oven walls: Enamel

Finish

Stainless Steel & Black

Built-in Lights

1

Connection

- Energy consumption conventional heating - Stove 1: 0.99 kWh
- Energy consumption convection / hot air - oven 1: 0.89 kWh
- Electrical connection value: 3200 W
- Hedging: 16 A
- Voltage: 220-240 V
- Frequency: 50-60 Hz
- Front color: stainless steel
- Energy Source: Electric
- Approval certificates: GS, CE, RCM
- Length of power cable: 100 in
- Length of connection cable: 100 cm
- Net weight: 33.0 kg
- Gross weight: 36.0 kg
- Connection Type: Hardwired

Accessories



Combination grate



Enamelled baking tray

Nikpol | 1300 645 765 | www.nikpol.com.au | sales@nikpol.com.au

Head Office (VIC) | 6-12 Fairchild Street Heatherton VIC 3202
QLD | 19 William Farrior Place Eagle Farm QLD 4009
NSW | 2/5 Bessemer Street, Blacktown NSW 2148